

Challenges when dealing with millions of pixels

Projection mapping



BARCO

**What is
projection
mapping?**



**From idea to
stage**



**Challenges to
deal with**



**Barco
solutions**



What is projection mapping?

Projection mapping is a video projection technique that creates the optical illusion of 3D effects on an object or building. The artistic play with light transforms virtually any surface into an immersive canvas and attention-grabbing experiences that captivate large audiences.



Then

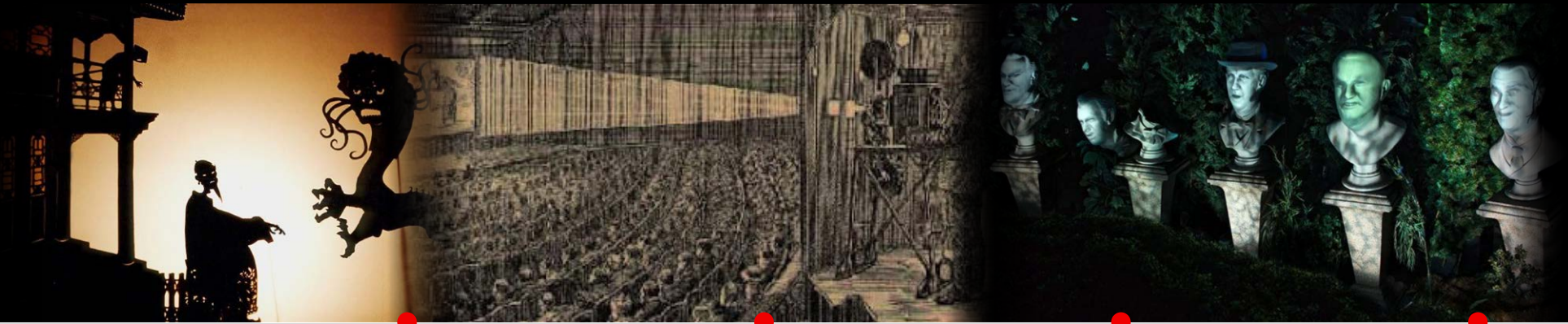

1800

1900

1950

2000

The creative use of light, images and canvasses can be found even in the earliest examples of story-telling entertainment, like shadow puppetry or phantasmagoria shows with magic lanterns.

During the technological revolution of the 19th century, projection was introduced to the larger public with movie screenings. The first to present projected moving pictures to a paying audience were the Lumière brothers in 1895. Soon cinema projection became a medium of mass entertainment and narrative communication.

With the arrival of televisions, and the ability to watch movies from the comforts of their own homes, audience expectations grew and the entertainment industry moved towards more immersive experiences.

The Disney company was a pioneer in the use of projectors to bring stories to life in a unique and immersive way. From the 360° Circarama theater to the first real example of 3D projection mapping. I.e. in the 1960s, the images of human faces were projected onto animatronics in the Haunted Mansion ride to make the lifeless busts look animated.

Now

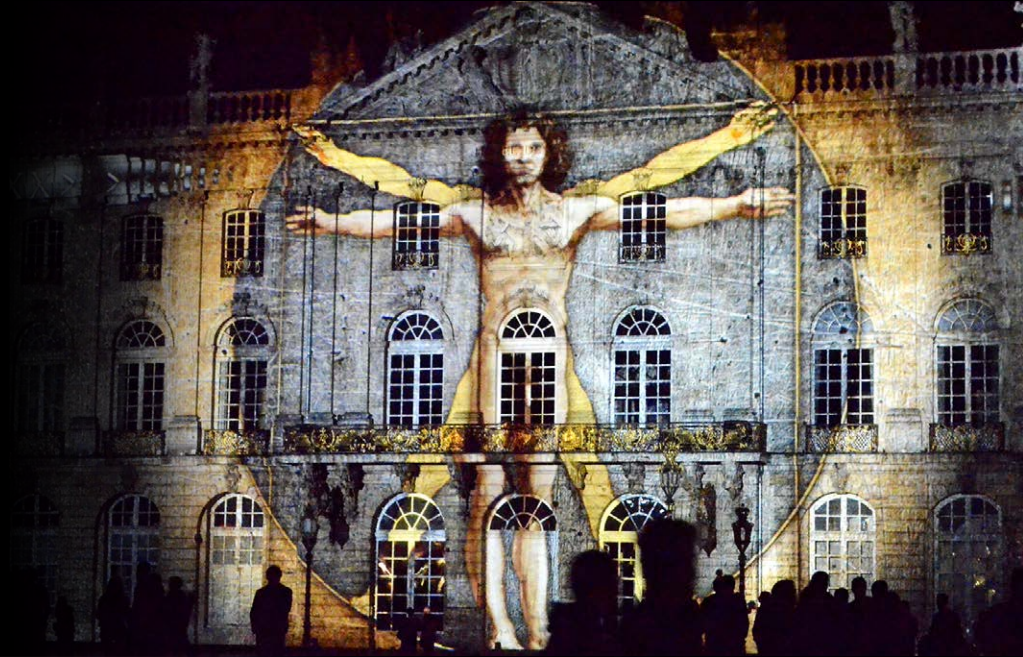

Since then, projection mapping found its way into various entertainment applications. Interactive dark rides, immersive museum exhibitions and spectacular theater staging. As the technology and projectors became more powerful, so did the ambition of the designers. The projections grow in scale and complexity.



Today projection mapping is especially popular as an urban art technique using public buildings and iconic landmarks as canvasses.



Technological magic

A large crowd of people is gathered at night, looking up at a massive, illuminated structure. The structure is covered in a vibrant, futuristic cityscape projection, featuring tall buildings and glowing lights. The scene is lit with blue and green light, creating a magical atmosphere. The crowd is silhouetted against the bright lights of the projection.

Projection mapping can be used for advertising, live concerts, theater, gaming, tradeshow, decoration... and really any other environment where you want that extra stopping power!

Unlike any other medium, projection mapping stands out as an extraordinary form of storytelling. Its impressive character and compelling form allows you to draw the attention of large crowds, and keep it, even from a distance.

It's technological magic, magical technology.

From idea to stage

From start to finish. From idea to stage.
This is how a projection mapping comes about.

IDEA



DESIGN



SET-UP



STAGE

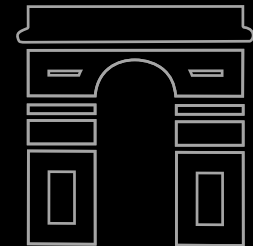
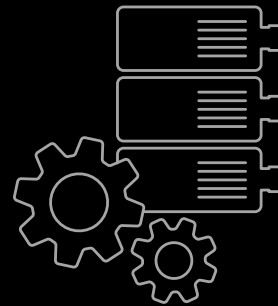
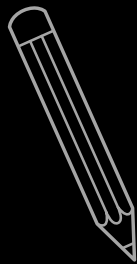

Everything starts during the first brainstorm with that one person who says: "Hey guys, what if we project a gigantic dancing teddy bear welcoming the children to the new toy museum". Or "What if we visualize the city's history on a mountain in the desert?".

Let your imagination run wild.

And then you're off! Turning those 'what ifs' into memorable realizations.

IDEA > DESIGN > SET-UP > STAGE

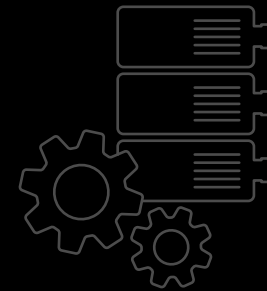
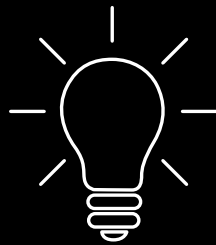



Elrow Town is a two-day festival where eccentricity and uninhabited extravagance is brought to life with giant inflatables, mad puppets, explosions of confetti, and pumping dance tracks that will leave your ears in ecstasy. How do you top this? By adding to the fun-filled mayhem with a jaw-dropping projection mapping spectacular!

Mike Radford
Audio Visual Project Manager at CPL

It goes without saying that there's a significant difference between projecting a 2D image onto a flat and uniform screen, and projecting onto medieval façades or monumental constructions which can vary in form, color, structure, etc. That's why projection mapping requires specialized software for content creation and previsualization.

The software integrates all necessary data of the imaging object and the surrounding to build up the project virtually. The previsualization teaches you a lot on how the light falls on certain angles and what the content looks like from different perspectives. This might save you lots of time and effort during the set-up itself.

IDEA > DESIGN > SET-UP > STAGE

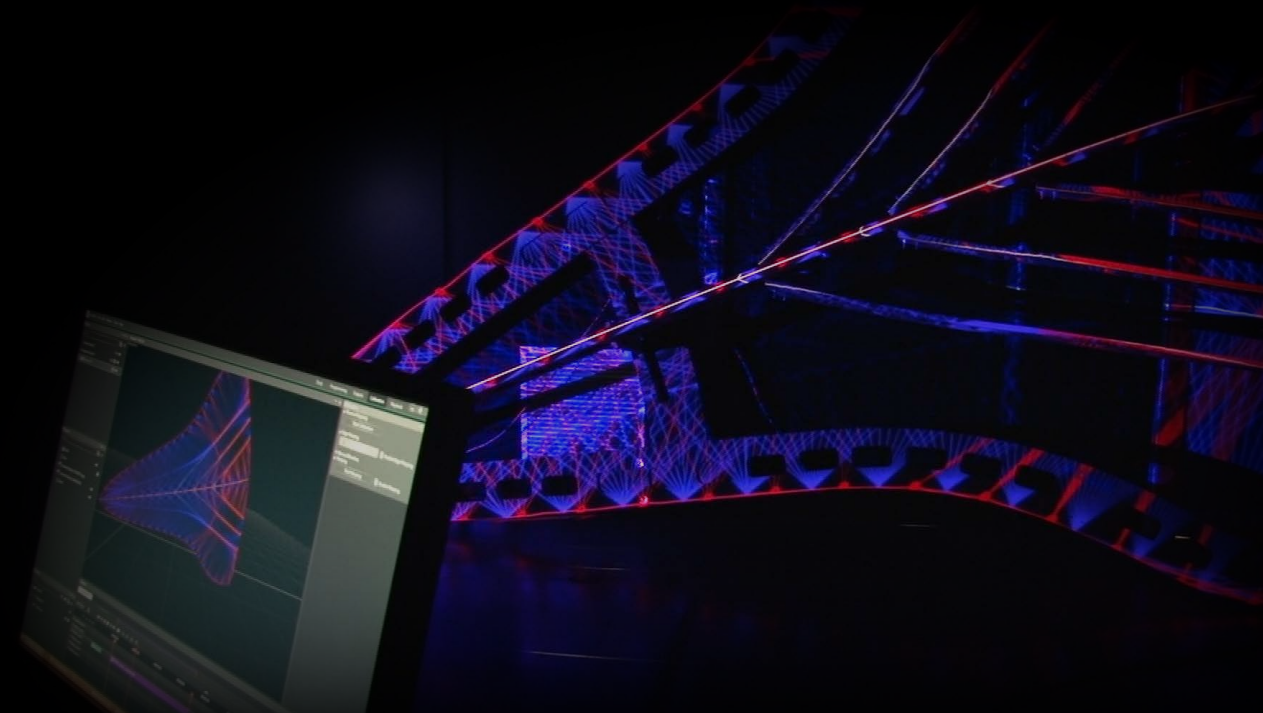
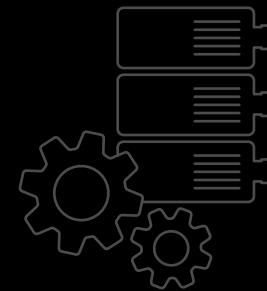
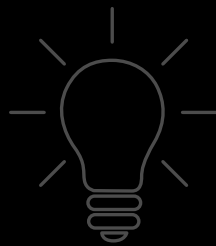



Working with the 3D media servers gives us far more accurate pre-production planning and projection studies, allowing us to deliver increased projection output. These 3D modelling features, together with a multi-skilled team, has helped us get sites up and running far more quickly and efficiently.

Steve Cain
Head Engineer and Media Server Specialist at TDC

And then it's time to scale it up. First, you'll need a processing system or media servers. These devices make sure the live projection mapping goes as planned, and the content hits the imaging object on all the right spots.

And ultimately, after putting all this hard work (and money) into show design and content creation, you need superb projection hardware that does justice to your efforts and brings your projection mapping to life in the best possible way.

IDEA > DESIGN > SET-UP > STAGE

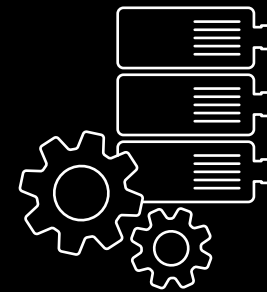
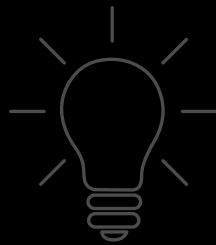

What's included in a typical set-up?

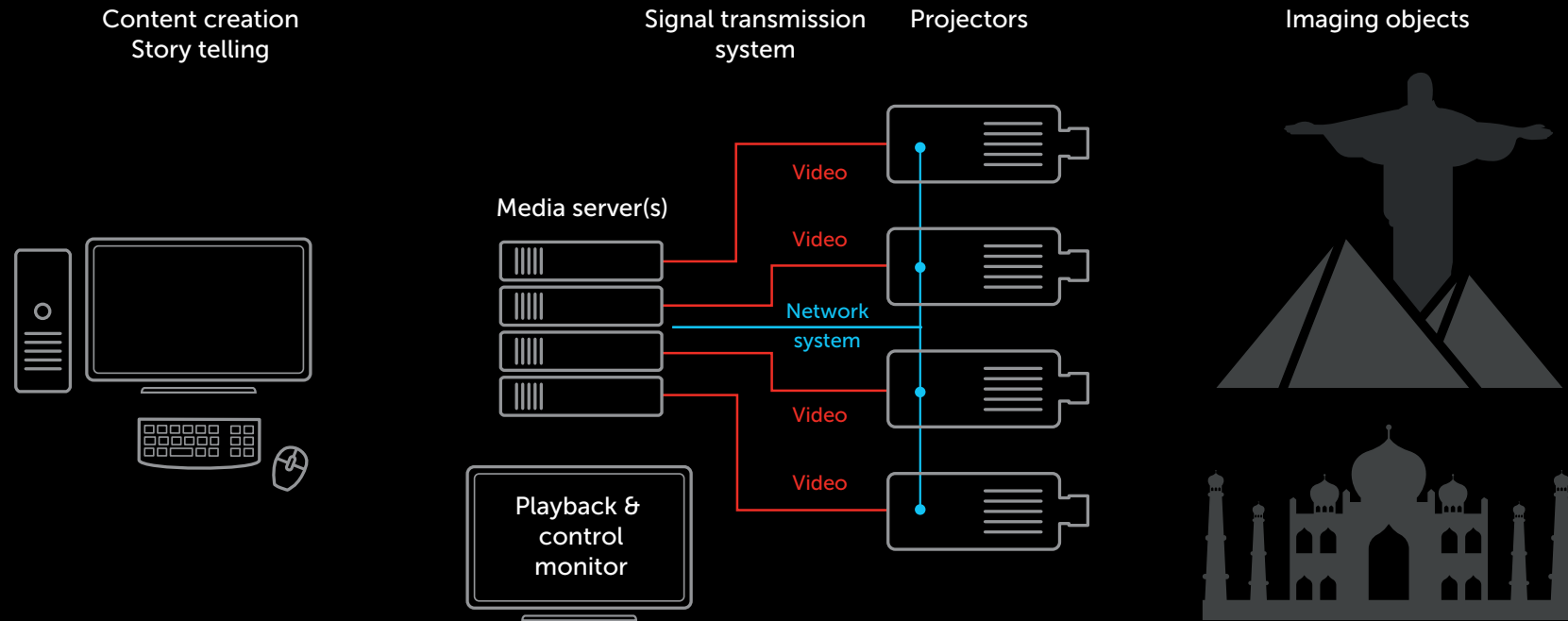

Relying on our track history of four decades in projection technology, the following pages of this e-book will be dedicated on the projection requirements to make your projection mapping successful.

For more indepth and technical information on how to set-up a professional projection system for mapping, read our [whitepaper](#).

If you're interested in more details on the other aspects of the chain, don't hesitate to reach out and we can put you in touch with one of our partners.

Here it is: your imagination come to realization.

From the creative design of mesmerizing video content, to the preliminary virtual renderings and intricate preparations of the installation, and eventually to the jaw-dropping live performance. When each part of the chain supports the other, it lifts your projection mapping to the next level.

IDEA > DESIGN > SET-UP > STAGE

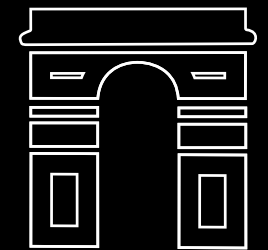
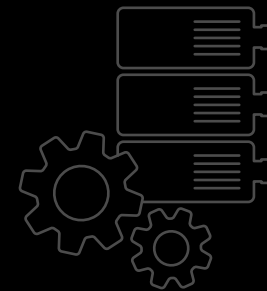
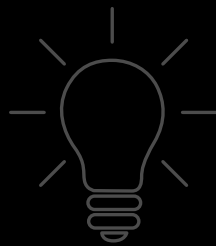



Given the scale of this project and the time-window of 60 days to finish, we realized that there will be some serious challenges ahead of us. But our team worked day and night to break all the walls we hit during the implementation. Seeing those 84 projectors producing a single blended image on the cliff for the first time was a breathtaking and unforgettable moment. It was all worth it.

Bilal Assidi
Martin Professional Sales Manager

Challenges when dealing with a million of pixels

Here are four important elements to keep in mind when choosing the right projector for your projection mapping.

#1. BRIGHTNESS

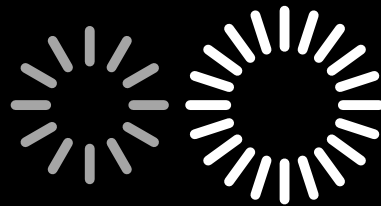

#2. COLORS

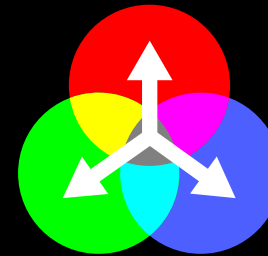

#3. RESOLUTION

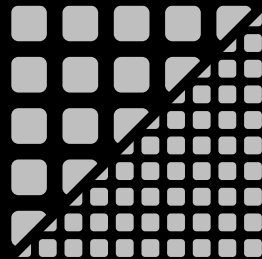

#4. PROCESSING

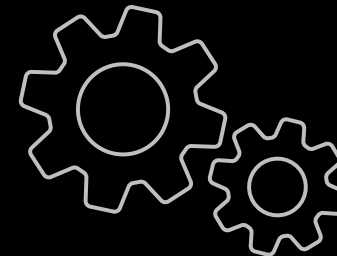

#1. Brightness



Fight light with light

Most outdoor projection mappings take place in the evening. Why? Because the sunlight affects the projection quality significantly. The external light conditions of your projection environment play a big part in the decision process. A high amount of ambient light will increase the request for more projector brightness.

For other applications in more dark environments, like indoor mappings on theatrical stages, brightness is less crucial, but nonetheless still an important criterion.

#1. Brightness

Lumens vs lux

Lumens is the amount of light emitted by the light source. But also not unimportant in deciding on the brightness of your projector is the projection distance and canvas width. That's when we talk about lux, which is the amount of light spread on the projection surface. In short, it's lumens per square metre.

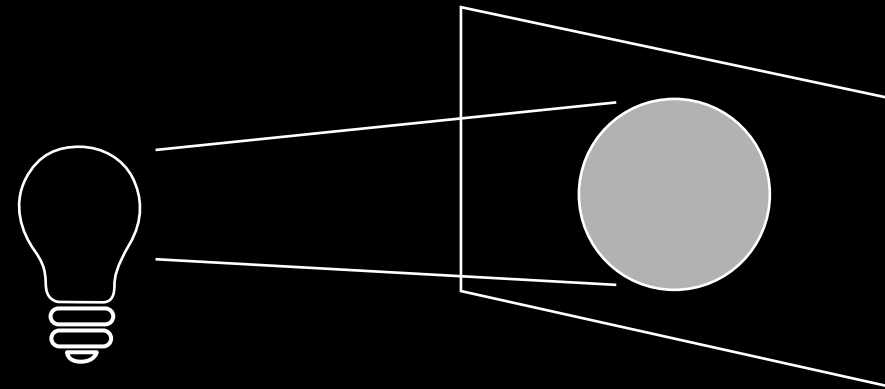

Light source
Lumen

#Lumens per m²
Lux

#1. Brightness

How bright should you go?

You can calculate the basic need of light output for your projection with following formulae. In order to reach sufficient brightness you might have to stack multiple devices.

$$\text{projector light output} = \left(\frac{\text{requested lux level}}{\% \text{ surface reflectivity}} \right) \times \text{width} \times \text{height of projection area}$$

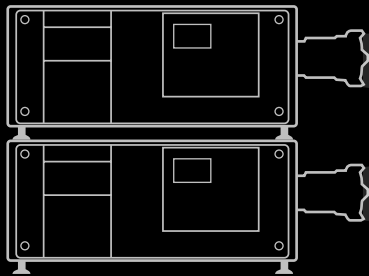

$$\frac{100 \text{ lux}}{25\%} \times 16\text{m} \times 10\text{m} = \mathbf{64,000 \text{ lumens}}$$

Example: 2x UDX-32K

#1. Brightness

See the light

Projection mappings are all about exposure. They're out there to impress everyone watching. Everyone! That is the live spectators standing open-mouthed in front of the canvas, but also viewers watching a recording online or on their television.

Taking in to account the basic viewing and broadcasting conditions, a higher projector brightness will get you better results. Notwithstanding, there are also other factors influencing the on-camera performance of your projection.



#2. Colors

Cover colors with more colors

A classic projection screen is typically white, because this reflects the projected light optimally. The image objects of projection mappings, however, come in all kinds of colors!

Now imagine trying to project an amazing bright blue underwater scenery on an industrial red brick façade. Your projector will need a high color performance to overrule the original colors of the building.



#2. Colors

Color gamut explained

The term color gamut is used to indicate how accurately a device can reproduce a certain range of colors from the entire color spectrum.

The most used way to represent color accuracy is by comparing color gamut triangles on the chromaticity diagram. The bigger the area that is covered by the triangle, the better the visualization device is at (re-)producing colors. For projection mappings a wide color gamut (REC.709 or more) is recommended for a realistic color reproduction of your content.

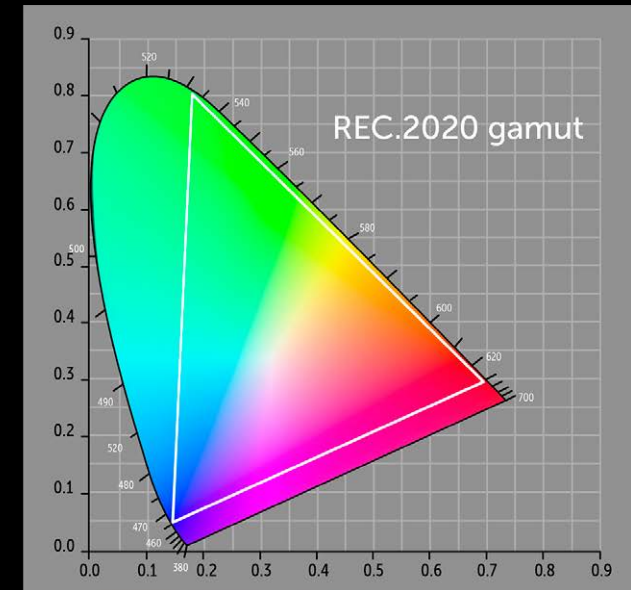
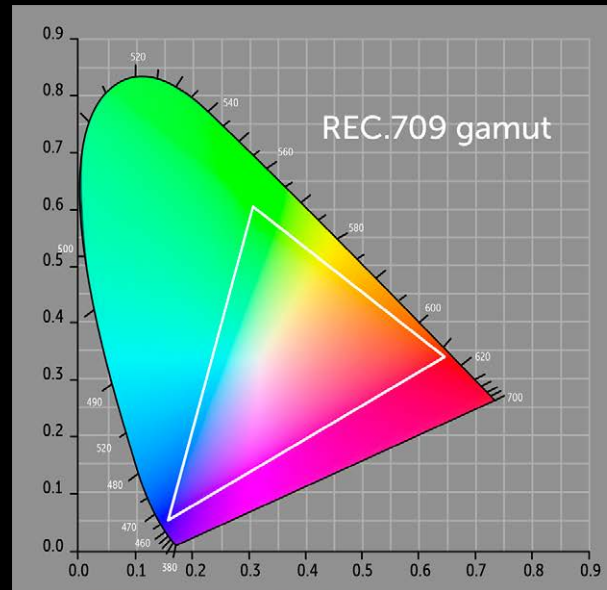

#3. Resolution

More pixels, more details

Higher resolutions convey more details and better image quality. Especially for indoor mappings, where audiences are often closer to the imaging object, a high resolution and accurate details are important to improve the overall experience.

Important to remember is that the resolution of your content is always limited to the maximum resolution of your projector. A WUXGA device will simply never be able to reproduce a 4K video. So resolution is definitely worth taking into consideration to realize the envisioned results.

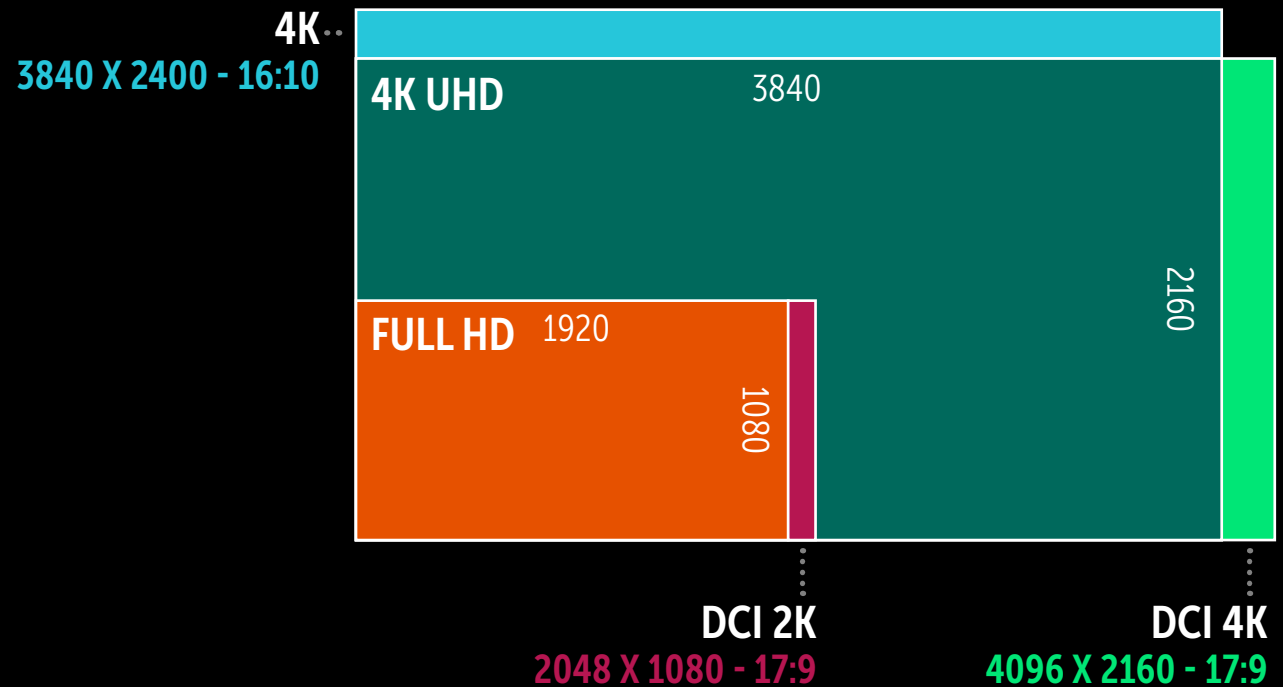

#4. Processing

A perfect mix of virtual images with the physical world

There are limits as to how much canvas one projector can cover. You can't project on, for example, the 420.000m² surface of the Hoover Dam with just a single projector. No. In many projection mapping cases, you will need multiple projectors. That's more pixels and more lumens for a truly immersive 3D effect.

And that's when things get critical, because you want those projectors to align perfectly and build a seamless image. As discussed earlier, preliminary studies on 3D models and a perfect physical set-up of the projectors certainly help, but what's really key here is relying on the right blending and warping software.



#4. Processing

Edge blending

Edge blending is the alignment of the projectors to remove the visible borders of the overlapping images for a seamless viewing experience.

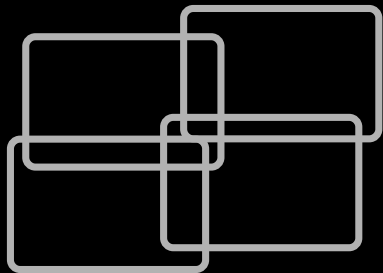
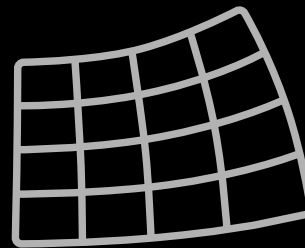

Image warping

Projector warping, also called geometric correction, is the process of digitally manipulating the image data to make it look correct on the specific projection surface or shape.



Checklist: How to choose the right projector?

BRIGHTNESS

COLORS

RESOLUTION

PROCESSING CAPABILITIES

For more technical details on projectors, check our [projection mapping whitepaper](#).

Barco solutions

Projectors

With a wide range of **brightness and resolutions**, and incredible **color accuracy** our projectors are able to cover varying surfaces.

1-chip laser phosphor projector



F80

- From 7K to 12K lumens
- Highly saturated colors that meet the Rec. 709 color space
- Versatile and ultra silent for indoor installation

3-chip laser phosphor projectors



UDM & UDX

- From 15K up to 45K lumens
- Stunning colors outperforming Rec. 709 spectrum
- Compact size saves time in installation and transportation

3-chip RGB laser projector



XDL

- Up to a massive 75K lumens
- Ultra-crisp contrast and extraordinary Rec. 2020 colors
- Life-like images with native 4K resolution up to 120Hz

Our projection line is also accommodated with all the necessary tools to enable efficient ways of working.



Barco Pulse

The beating heart of our projectors

- 4K Ultra High Definition (UHD) processing
- High-quality warping and blending capabilities embedded in the projector software
- Market leading lowest latency as all image processing is done through the proprietary Barco Single Step Processing technology.
- An intuitive user interface which allows you to set up your installation quickly and easily

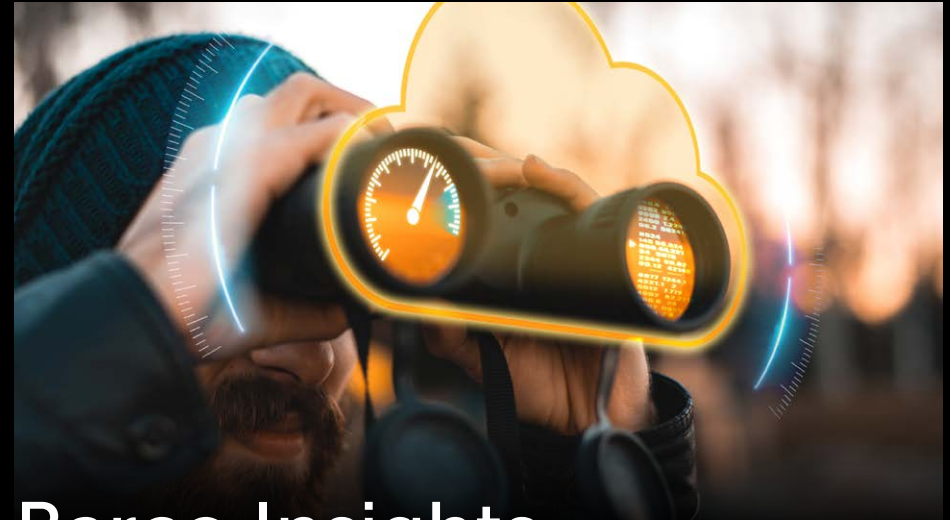

Barco Insights

Enhanced remote fleet management

- Cloud-based storage of projectors' usage data and their light-source run-times for stress-free administration
- Live dashboard gives real-time information on the operating and environmental conditions of the projectors for effective device analysis
- Access on any device with internet access

Lenses

We have a full range of lenses available for various throw distances.

Lens shift

With our wide lens shift, you fit your equipment to the show, not the other way around.

Orientation

Thanks to the 360° orientation flexibility of our projectors, and the additional rotation capabilities of the UST lenses, stacking is a piece of cake.

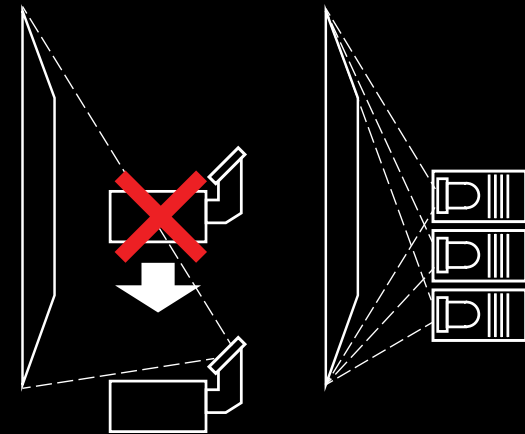
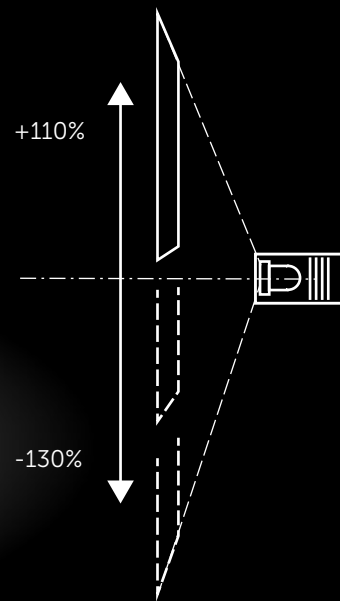

Peripherals

Next to the lenses, Barco offers an extensive list of additional projection accessories enabling the flexibility to deliver superior quality in the most diverse setups without complicating the process for your crew members.

The motorized rental frame, for example, offers an easy solution for stacking and hanging projectors, and allows for quick remote adjustments. In addition we also have protection cases in our portfolio to keep your projectors safe from dust, sun and the whims of the weather.



Presentation switchers

With performance second to none and ultra-low latency, our video processing and presentation switchers are the benchmark in the industry for image and processing. Their modular and future-proof architecture makes them perfect for all events. Size the system to your event.



E2

Supporting native 4K input and output, the E2 is the first screen management system to manage 4K projector blends with refresh rates up to 60Hz with full 4:4:4 color sampling and 12bit processing. A truly versatile system, it offers sixteen 4K inputs and eight 4K outputs for full show control within a single box.



S3

The S3 is the E2 image processor's more compact sidekick. Under the hood, however, it boasts the same processing performance, image quality, flexibility and rugged durability. In short: all the tools you need to create a stunning live experience, in a single compact and roadworthy housing.



PDS-4K

The PDS is designed to meet today's requirements for a high-quality, easy-to-use and fast seamless switching with more digital inputs at an affordable price. Thanks to its straightforward setup and operation, the PDS is a perfect fit for smaller to mid-sized setups.

Reference story

Qiddiya

Saudi Arabia is an ambitious nation with a vision! More specific Vision 2030. With this national blueprint they are building on a vibrant society and a thriving economy with a strong focus on tourism and recreation. A first major realization was revealed to the public with a giant mountainside projection on the Tuwaiq mountains during the closing ceremony for the Dakar rally 2020. 84 (!) UDX-W40s were used to transform the mountain surface into a dramatic backdrop.

The challenges of projecting a uniform image on a natural canvas with an irregular structure are manifold. The key factor to success was the active collaboration between Barco and the other involved parties throughout the entire journey – teaming up together from prior studies of the mountain, to content design, projection setups with specially developed mounting kits and eventually the live show. In the end onlookers were amazed with the mind-blowing result.

Barco solution:
UDX-W40

Key benefits:

- Stunning experiences thanks to high-brightness images
- Outstanding color performances
- Robust design to withstand the outdoor desert environment

[Read more >](#)



Reference story

Atelier des Lumières

Barco and Culturespaces have an impressive record together teaming up towards innovative and immersive multi-media museum experiences. In their Atelier des Lumières (Paris) they immerse visitors in an alternate world filled surrounded by images and music. Thanks to very large-format projection mappings that cover the walls, the floor and the ceiling in high definition, the art lovers walk right inside the works. About 140 Barco laser projectors are now used to depict thousands of extremely precise and detailed images on a surface area of 3,300 square metres.

Barco solution:

F80

Key benefits:

- Razor-sharp quality depicting the art works in the most lifelike way possible
- Images that run 24/7
- The perfect price-performance ratio

[Read more >](#)



Reference story

Xiahuayuan District

The Xiahuayuan District in the city Zhangjiakou has an extensive history. It was once a Royal Garden, was home to a coal-fired power plant for many years and has also been converted into a heat-generating unit. Today, there are plans to draw tourists to the area by establishing it as a landmark. And the Local Real estate Company- Ansheng Group decided to do this with a 3D mapping show broadcast on three cooling towers. They asked Barco to help make the project come to life.

The projections included a dragon that burst out of the tower, an enormous whale in an undersea environment and tower bricks that realigned themselves at will. The outside of the tower even stretched like fabric before crumbling into dust. It all looked authentic, but once the presentation finished, the tower was still standing there, as sturdy as ever, without a single dragon in sight.

Barco solution:
UDX-W32

Key benefits:

- Constant brightness and the widest color spectrum
- Breathtakingly sharp and focused images
- Professionalism, service and speedy response of the Barco team

[Read more >](#)



Reference story

Seoul Light

The Dongdaemun Design Plaza (DDP) is a major urban development landmark in Seoul, South Korea. The architectural grandeur lies in the distinctively neo-futuristic design, characterized by the powerful, curving forms of elongated structures. For the 'Seoul Light' festival, the organizers wanted to enthrall audiences with a projection mapping on the silvery outer wall. The objective was to capture the pulse of the city through an expression of public narratives, using art and technology. Barco's projectors beautifully unfolded the inaugural theme of Seoul Haemong' - showcasing the past, present and future of Seoul and Dongdaemun.

Barco solution:
UDX-4K32

Key benefits:

- Dazzling high-resolution images
- Reliability that offers complete peace of mind throughout the event
- Flexibility to project on varying surfaces

[Read more >](#)



Reference story

Artehouse

ARTEHOUSE is an innovative art space, with permanent locations in DC, Miami, and NYC. It is home to 21st-century artists who work with innovative technology and new forms of creative expression. By leveraging Barco's various product solutions, ARTEHOUSE is able to bring contemporary art to life and offer an exclusive sensory experience of technologically powered works that allow guests to explore art in an entirely new way.

Barco solution:
**UDX-4K32
& F80**

Key benefits:

- Incredibly consistent color performance
- Durable laser technology that can withstand daily long operations hours
- Great support from the Barco team

[Read more >](#)

Conclusion

Projection mapping is the key towards strong storytelling, innovative marketing and just all-round entertainment. However, it does require skills and well-thought-out planning to create that visual feast you envision.

Only by using the right technology, can you do justice to your specifically designed breathtaking content. And with equipment that excels in flexibility, no set-up is too challenging.

Thanks to Barco's visualization solutions you can let your creativity run free and get that mind-blowing result you had in mind!

Discover our solutions at www.barco.com/projection-mapping

Or [get in touch](#) to discuss how Barco can help you with your next projection mapping.